

**AGENDA**

**CALL TO ORDER**

**PLEDGE & PRAYER**

**ROLL CALL**

**OLD BUSINESS**

**NEW BUSINESS**

Resolution no. 8865 – Authorizing the Mayor to Reserve for Purchase a TFD Rescue Vehicle

**PUBLIC COMMENTS**

**ADJOURN**

CITY COUNCIL OF THE CITY OF TARRANT, ALABAMA

RESOLUTION NO. 8865

**A RESOLUTION AUTHORIZING THE MAYOR TO RESERVE FOR PURCHASE ONE (1) 2022 DODGE RAM 5500 CREW CAB RESCUE VEHICLE FOR THE CITY OF TARRANT'S FIRE AND RESCUE DEPARTMENT.**

**BE IT RESOLVED** by the City Council of the City of Tarrant, Alabama while in a Special Called Meeting on Friday, February 11, 2022 at 5:30 pm as follows:

**Section 1.** That the Mayor is authorized to sign any required agreement to Reserve for Purchase a Rescue Vehicle for use by the Tarrant Fire and Rescue Department; and

**Section 2.** That the purchase of one (1) 2022 Dodge Ram 5500 Crew Cab and Chassis for the Tarrant Fire and Rescue Department is hereby authorized; and

**Section 3.** That said 2022 Dodge Ram 5500 Crew Cab and Chassis, as described in **Exhibit A**, will be purchased from North American Fire Equipment Company (NAFECO); and

**Section 4.** That said expenditures, not to exceed \$175,000.00, shall be made from the City of Tarrant's General Fund.

APPROVED AND ADOPTED THIS THE 11TH DAY OF FEBRUARY, 2022

APPROVED:   
Wayman A. Newton, Mayor

ATTEST:   
LaShawn Pegues, City Clerk

**CERTIFICATION OF CITY CLERK**

STATE OF ALABAMA     )  
JEFFERSON COUNTY    )

I, LaShawn Pegues, City Clerk of the City of Tarrant, Alabama, do hereby certify that the above and foregoing is a true and correct copy of a Resolution duly adopted by the City Council of the City of Tarrant, Alabama, on the 11<sup>th</sup> day of February, 2022.

Witness my hand and seal of office this 11<sup>th</sup> day of February, 2022.

  
LaShawn Pegues, City Clerk

**EXHIBIT**

**A**

## Proposed Replacement Rescue Unit

- R-77 was wrecked November 4, 2021
- We have been communicating with AMIC (ins Co) since then to get this resolved
- We are currently utilizing Car 39 a pickup truck to run medical only off of and an engine. We cannot run rescue off C39 due to it won't carry all our equipment
- I have been searching for nearly 3 months for a Stock unit or getting pricing and timelines from manufactures, (COVID has severely affected pricing and availability of apparatus)
- The lowest quotes I have received were in the \$199,000 - \$203,000 to as high as \$300,000 for a rescue unit
- Timelines are in the 18-24 month minimum to they wont even give me a timeline range
- We have been quoted \$ 168,682.00 for this Stock Unit Rescue that would be configured for Tarrant FD, the chassis is on site at the Rosenbauer Plant and they have started construction this week on the rescue box for the chassis.
- This NAEFCO stock unit #42603 is scheduled for completion in late April.

INITIALS: -  
 JOB NUMBER: 42603  
 DATE: -

MAIN FILE: -  
 DEPT: -  
 DEALER: -

PRODUCTION APPROVED

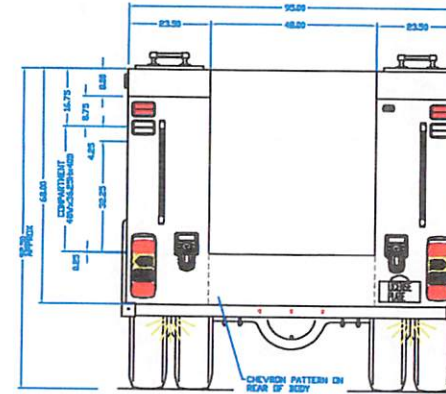
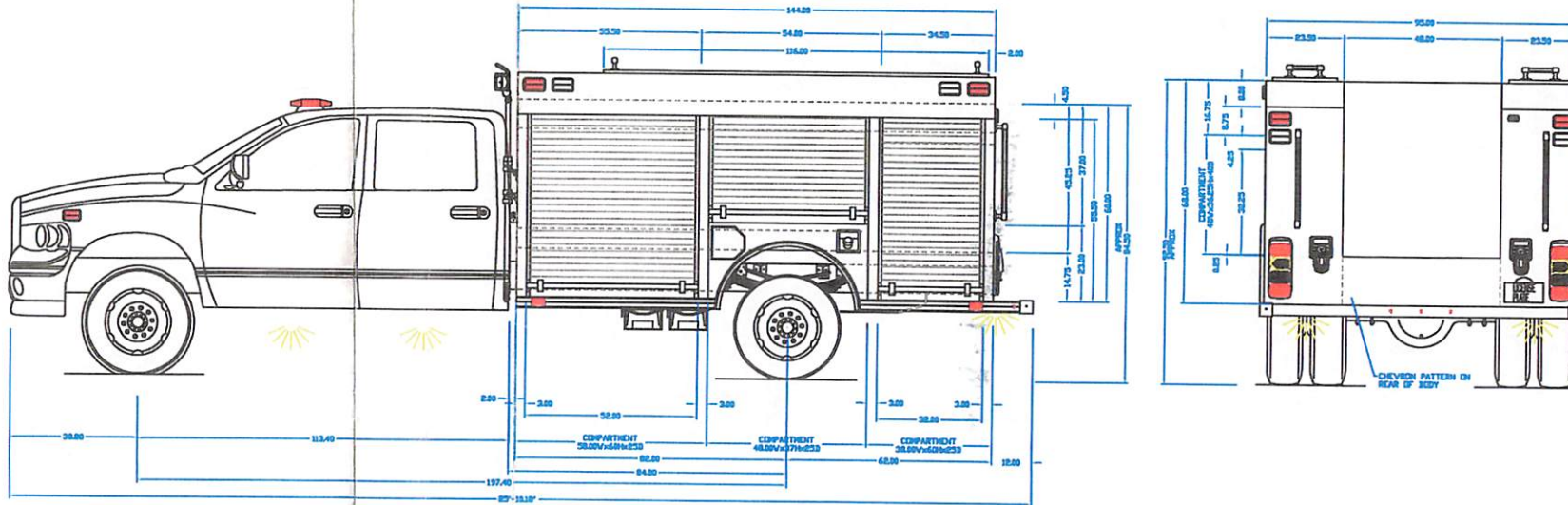

- NOTES:
1. OVERALL HEIGHT IS IN LOADED CONDITION. UNLOADED HEIGHTS MAY BE 4" ABOVE HEIGHTS SHOWN.
  2. DO NOT SCALE DRAWING.
  3. ALL DIMENSIONS ARE APPROXIMATE AND SUBJECT TO ENGINEERING CHANGES.
  4. DRAWING MAY OR MAY NOT SHOW ALL ITEMS AS DESCRIBED IN THE WRITTEN DETAIL SPECIFICATIONS.
  5. INCLUSION OF AN ITEM ON THE DRAWING DOES NOT CONSTITUTE INCLUSION OF THAT ITEM WITH THE FINAL DELIVERED UNIT.
  6. THE EFFECTIVE DOOR OPENINGS WILL BE APPROX. 2" LESS THAN THE NOTED COMPARTMENT OPENING FOR ROLL UP DOORS AND UP TO APPROX. 4" LESS FOR HINGED DOORS

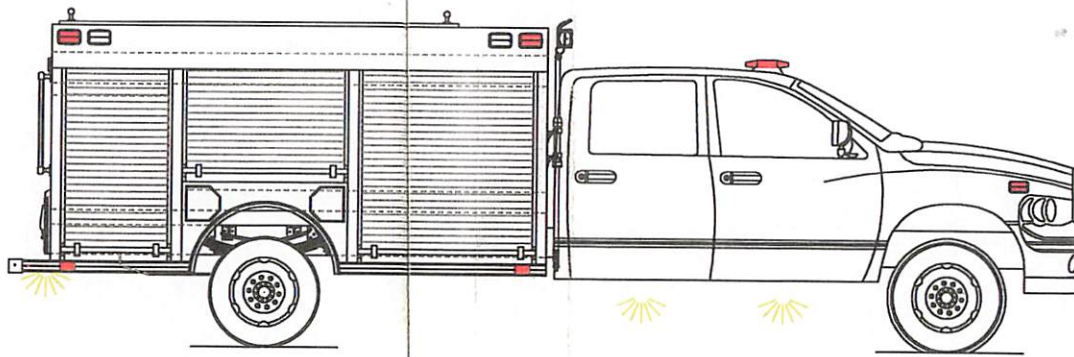

APPROVED BY: \_\_\_\_\_  
 CHASSIS: DODGE  
 PUMP: NONE  
 TANK: NONE  
 PANEL MATL: NONE

REVISED -	DATE -
DRAWN -	DATE 11/17/2011

COMP INTERIOR: SWIRL	
MAXIMUM HEIGHT	NONE
MAXIMUM LENGTH	NONE
BODY WIDTH	98"

PROPRIETARY AND CONFIDENTIAL  
 THE INFORMATION CONTAINED IN THIS DRAWING IS  
 THE SOLE PROPERTY OF ROSENBAUER. ANY  
 REPRODUCTION IN PART OR AS A WHOLE WITHOUT  
 THE WRITTEN PERMISSION OF ROSENBAUER IS  
 PROHIBITED.

STOCK DODGE



MINI RESCUE 3/16"

STOCK DODGE MINI 4X4

**vd: Dodge 5500 Stock Unit**

message

TarrantFire <ittarrantfire@yahoo.com>  
Tarrant Fire <tarrantfire@gmail.com>

Fri, Feb 11, 2022 at 3:52

Patrick Bennett

Begin forwarded message:

**From:** Doris Thrasher <doris.thrasher@nafeco.com>  
**Date:** February 11, 2022 at 15:27:51 CST  
**To:** pbennett@cityoftarrant.com  
**Cc:** John Wilson <john.wilson@nafeco.com>, Adam Terry <adam.terry@nafeco.com>, Joe Davis <joe.davis@nafeco.com>  
**Subject:** Re: Dodge 5500 Stock Unit

Patrick:

As per our conversation, the full spec (excluding the enclosure and the items listed below) and the drawing are attached.

Pricing to include \$1,500.00 lettering allowance: \$168,682.00 (Please note: should the graphics be less than the allowance, the balance will be credited back to the fire department).

Thank you. Have a great day.

Doris Thrasher  
Apparatus Sales Manager  
NAFECO  
1515 West Moulton Street  
Decatur, AL 35601  
Office: (800) 628-6233 ext. 155  
Direct Line: (256) 580-6818  
Fax: (256) 355-0852  
Email: doris.thrasher@nafeco.com  
Visit us on the web at www.nafeco.com

On Fri, Feb 11, 2022 at 2:17 PM Doris Thrasher <doris.thrasher@nafeco.com> wrote:

Good Afternoon Patrick.

As per our conversation earlier today, in addition to enclosing the rear compartment the following changes were requested:

- Add 1000# slide out tray in the rear compartment, 100% extension
- Add adjustable tray in compartment(s) L2, L3, R2, R3
- Add floor extension in compartment(s) L1/R1
- Delete wheel chocks
- Delete telescoping lights
- Add running boards (already included)

Additionally, you had asked to remove the grab rails on the rear. Unfortunately, we weren't able to remove those due to needing access points to reach the upper compartments. We also had to add folding steps on the rear for those compartments since we are enclosing what would essentially have been one of the stepping surfaces.

With that said, the final price with all the changes and deletions listed above totals \$167,182.00.

If you should choose to purchase the truck on either the HGAC or Sourcewell contract, there would be an additional charge of \$2,000.00.

At present, the truck is tentatively scheduled for completion in late April.

Please let me know if you have any questions or if any additional information is needed.

Thank you. Have a great day.

Doris Thrasher  
Apparatus Sales Manager  
NAFECO  
1515 West Moulton Street  
Decatur, AL 35601  
Office: (800) 628-6233 ext. 155  
Direct Line: (256) 580-6818  
Fax: (256) 355-0852  
Email: doris.thrasher@nafeco.com

---

**2 attachments**

 **STOCK DODGE MINI 4X4 Updated DWG.pdf**  
185K

 **42603 Dodge 5500 Quick Attack Stock Unit Specifications 1-20-2022.docx**  
90K



A division of ClaimSolution Inc.

Prepared for EVERS AND ASSOCIATES-AUTO BID	Date 12/07/2021
Adjuster JAKE DILLASHAW	ACV \$81,062.76
Requested by JAKE DILLASHAW	Aftermarket Parts \$0.00
Appraiser File No JD21-121600	Refurbishment \$0.00
Claim No 56633	Prior Damage \$0.00
Auto Bid ID B163235	

Final ACV **\$81,062.76**

**Vehicle Detail**

Year 2017	VIN 1FDUF5HT6HEB62060
Make FORD	Mileage 22,389
Model F-550 4WD	Loss Date 11/04/2021
Style/Body REGULAR CAB; CHASSIS; RESCUE TRUCK	Market Area (Tax Rate) BIRMINGHAM, AL
Transmission AUTOMATIC	Claimant/Owner TARRANT FIRE DEPARTMENT
Engine V8, 6.7L; TURBO	

**Condition**

Drivetrain AVERAGE	Interior AVERAGE
Tire AVERAGE	Exterior ABOVE AVERAGE
Condition Note	

**Equipment List**

**NADA Values**

<b>Retail</b>	<b>Vehicle Adjustment</b>	<b>Option</b>
Base \$39,250.00	Mileage 22,389	Option Total \$4,650.00
Adjusted \$52,088.00	Adjustment \$8,188.00	(4650) 4WD OR AWD

**Comments**

	Comp Vehicle One	Comp Vehicle Two	Comp Vehicle Three
Dealer/Owner	LARRY STIGER'S EQUIPMENT	NYE MOTOR COMPANY	CENTURY TRUCKS & VANS
Contact	866-383-0394	866-390-2568	469-416-3679
Address	FRANKFORT KY	MANHEIM PA	GRAND PRAIRIE TX
Distance	337 MI	728 MI	595 MI



License Plate			
Stock Number			
VIN			
Year	2017	2017	2017
Make	FORD	FORD	FORD
Model	F-550 4WD	F-550 2WD	F-550 2WD
Style	REGULAR CAB; CHASSIS; RESCUE TRUCK	REGULAR CAB; CHASSIS; RESCUE TRUCK	REGULAR CAB; CHASSIS; RESCUE TRUCK
Engine	V8, 6.7L; TURBO	V8, 6.7L; TURBO	V8, 6.7L; TURBO
Mileage	119,000	116,150	102,106
Drivetrain Condition	AVERAGE	AVERAGE	AVERAGE
Tire Condition	AVERAGE	AVERAGE	AVERAGE
Interior Condition	AVERAGE	AVERAGE	AVERAGE
Exterior Condition	AVERAGE	AVERAGE	AVERAGE
Exterior Color			
Equipment List	6.7L TURBO DIESEL AUTOMATIC 4WD A/C AM/FM CRUISE DUAL AIR BAGS DUAL REAR WHEELS POWER BRAKES POWER LOCKS POWER STEERING POWER WINDOWS TILT WHEEL TINTED WINDOWS	6.7L TURBO DIESEL AUTOMATIC 2WD A/C AM/FM CRUISE DUAL AIR BAGS DUAL REAR WHEELS POWER BRAKES POWER LOCKS POWER STEERING POWER WINDOWS TILT WHEEL TINTED WINDOWS	6.7L TURBO DIESEL AUTOMATIC 2WD A/C AM/FM CRUISE DUAL AIR BAGS DUAL REAR WHEELS POWER BRAKES POWER LOCKS POWER STEERING POWER WINDOWS TILT WHEEL TINTED WINDOWS
Total Price	\$46,900.00	\$34,950.00	\$46,975.00

	Comp Vehicle One	Comp Vehicle Two	Comp Vehicle Three
Equipment Adjustment	\$33,220.50	\$37,870.50	\$37,870.50
	2005 FIRE RESCUE BODY: \$25,000.00	4WD: \$4,650.00	4WD: \$4,650.00
	REFURBISHMENTS @ 50%: \$8,220.50	2005 FIRE RESCUE BODY: \$25,000.00	2005 FIRE RESCUE BODY: \$25,000.00
		REFURBISHMENTS @ 50%: \$8,220.50	REFURBISHMENTS @ 50%: \$8,220.50
Adjustment cents per mile	\$1,932.22	\$1,875.22	\$1,594.34
Adjustment price	\$82,052.72	\$74,695.72	\$86,439.84

**Autobid Comments**

---

**Carfax Title History Report**

Year 2017  
Make FORD  
Model F550 SUPER DUTY  
Last Odometer Reading 22,755  
Title History ACCIDENT, RECALL

**AUTO BID – Certified Vehicle Valuation**